



INSTALLATION & OPERATION MANUAL

VTC1550 VOLTAGE CONVERTER



//MDS POWER[®]

VOLTAGE CONVERTERS

IMPORTANT SAFETY INSTRUCTIONS

SAVE THESE INSTRUCTIONS — This manual contains important safety and operating instructions for the voltage converter.

VOLTAGE CONVERTER PRECAUTIONS

1. Do not expose the voltage converter to rain or snow unless it is a sealed model.
2. Use of an attachment not recommended or sold by the manufacturer may result in a risk of fire, electric shock, or injury to persons.
3. Do not disassemble the voltage converter. If service or repair is required, return it to the manufacturer or an authorized service center. Incorrect reassembly may result in a risk of fire or electric shock. Voltages up to 350 volts are present inside the voltage converter any time it is connected to input power, even if it is switched OFF.
4. To reduce risk of electric shock, disconnect the voltage converter from the input power before attempting any maintenance or cleaning. Switching the voltage converter to OFF will not reduce this risk.
5. Never place the voltage converter directly above a battery; gases from the battery will corrode and damage the voltage converter.
6. Never allow battery acid to drip onto the voltage converter.

WARNING: Do not use this product to charge a battery. It does not have the circuitry or programming to properly or safely charge a battery. Both the voltage converter and the battery could be damaged or destroyed!

MEDICAL EQUIPMENT NOTICE

This unit is not recommended for use in life support applications where failure or malfunction can be reasonably expected to cause failure of the life support device or to significantly affect its safety or effectiveness. This unit is not recommend the use of any of its products in direct patient care. Examples of devices considered to be life support devices are neonatal oxygen analyzers, nerve stimulators (whether used for anesthesia, pain relief, or other purposes), auto-transfusion devices, blood pumps, defibrillators, arrhythmia detectors and alarms, pacemakers, hemodialysis systems, peritoneal dialysis systems, neonatal ventilator incubators, ventilators for both adults and infants, anesthesia ventilators, and infusion pumps as well as any other devices designated as "critical" by the U.S. FDA.

TABLE OF CONTENTS

- Front Cover, Product Photo and Title
- Product Warnings and Advisories
- Table of Contents
- Introduction
- Box Contents
- Main Parts
- Operation
- Installation
- Troubleshooting
- Specifications
- Warranty

Introduction

The VTC1550 Voltage Converters provides up to 1500 watts continuous and 1800 watts intermittent to power one or more loads from a 100-400 VDC source.

Two positive and two negative output connections are provided for easy connection to multiple devices. The recently updated single board design incorporates power factor correction technology for unmatched efficiency. Multiple stages of filtering reduce radiated and conducted noise to MIL461 levels for ultra-quiet operation.

Safety features include over-temperature shutdown, current limiting, short circuit protection with automatic recovery, input under voltage shutdown, reverse polarity connection protection and output over-voltage protection. Extra features include visual indicators for low input voltage, overload and overtemperature, dry contact output fail output and remote control connection.

Box Contents

The box you have received should contain the following:

- One VTC1550 voltage converter
- One USB cable
- This User guide
- One warranty registration card

If anything is missing from the box or is damaged please contact your dealer for a replacement.

Main Parts

Front Panel



1. Indicator LEDs
2. **DC Output Connection:** 2x Phoenix VDFK Terminal Block Connections (Red: Positive, Black Negative)
3. Output Voltage Adjust
4. **DC Power Input Connection:** 1ft/30cm Type-D #12AWG Stranded Input Leads (Red: Positive, Black Negative)
5. Power Switch
6. Input Fuse

Rear Panel

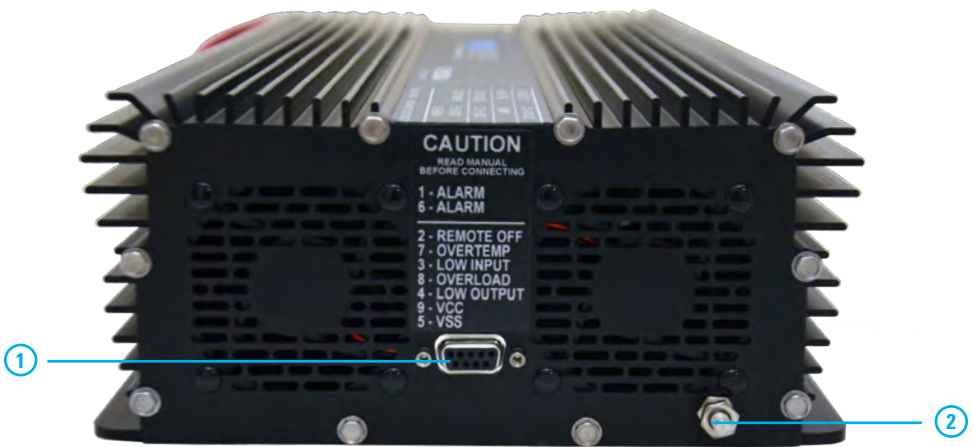

1. Remote Control Connection
2. Chassis Grounding Stud

Operation

This voltage converter is designed for simple operation. Before operating, the unit must be properly installed and connected. See *Installation* for more information regarding mounting and connections.

TO POWER A LOAD

1. Move the power switch to ON. The alarm buzzer will sound and the LOW VOLTAGE OUTPUT LED will glow red briefly, then the POWER LED will glow green. This is normal.
2. The unit will automatically supply the connected load with the voltage listed on the unit label for as long as it is connected.

TO ADJUST THE OUTPUT VOLTAGE

3. Locate the Output Voltage Adjustment potentiometer on the front panel. On some units, this is covered by a protective cap to prevent accidental operation.
4. Rotate the knob to adjust the charging voltage. The output voltage can be adjusted over a range of ± 1.0 volts.
5. Rotate the potentiometer clockwise to increase the charging voltage; counterclockwise to decrease the voltage.
6. Using a multimeter, read the charging voltage at the output terminal. On units with the optional digital multimeter, that can be used to read the voltage instead.
7. When satisfied with the new voltage reading, restore the protective cap in place if needed.

TO END OPERATION

1. Move the power switch to OFF.
2. Wait for all the Indicator LEDs stop glowing.
3. It is now safe to disconnect the unit from the power source and load. The unit is now ready for storage or service.

Installation

MOUNTING

This unit weighs approximately 20lbs (9.1 kg) and can be safely mounted on either a horizontal or vertical surface. Mount the unit in a dry and well-ventilated location at least 1 inch (2.54 cm) surrounding clearance.

The W-series models are designed to meet IP66 rating, and is resistant to water spray from any direction. These units can be mounted in wet locations but are not suitable for submersion.

The Y-series models are designed and certified to meet IP67 rating. These units are resistant to water immersion of a depth up to 1 meter for 30 minutes and suitable for mounting in locations such as a vehicle fording a river.

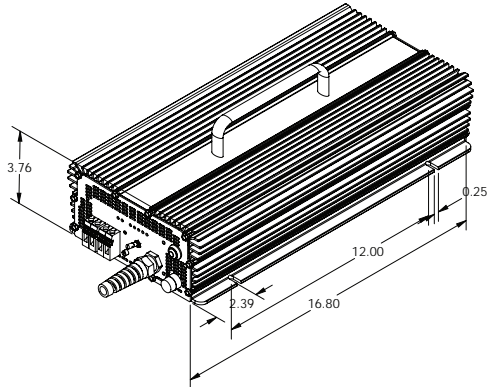

CAUTION: NEVER CONNECT OR DISCONNECT ANYTHING TO THE UNIT'S INPUT OR OUTPUT WHILE IT IS ON!

To prevent the risk of high voltage electric shock, never connect or disconnect anything to/from the unit's input or output connections while the power switch is ON.

DISCONNECTING

If you need to disconnect the unit for service or storage:

1. Move the power switch to OFF and disconnect the power source and load
2. With power disconnected, move the power switch to ON.
3. Leave the switch in this position for one minute to discharge the storage capacitors.
4. Return the power switch to the OFF position.
5. The power supply or battery charger is ready for service or storage.

DC INPUT

The DC Input Connection is intended for connection to DC power source. To ensure normal operation, the power source must be suitably rated for the voltage converter. The rated input voltage and current values can be found on the unit label located on the top panel. For more information, regarding input specifications, see the *Specifications* section.

This unit is equipped with two 1.0m/3.0 ft AWG12 color-coded power cables to serve as a DC Input Connection. This polarity of this connection is as follows:

| Connector Color | Polarity |
|-----------------|----------------|
| Black | Negative |
| Red | Input Positive |

DC OUTPUT

The DC Output Connection is intended for connection to load. To ensure normal operation, the total average connected load should not exceed this unit's continuous output amps rating. Some units may require wiring to the output connection. To help determine suitable gauge of wiring, the rated output voltage and current values can be found on the unit label located on the top panel. For more information regarding output power specifications, see the *Specifications* section.

This unit is equipped with two sets of Phoenix VDFK terminal block connectors to serve as a DC Output Connection. If powering multiple loads, they must share a common ground. This polarity of this connection can be found on the front panel label and is also as follows:

| Connector Color | Polarity |
|-----------------|-----------------|
| Black | Negative |
| Red | Output Positive |

CAUTION: NEVER CONNECT THE LOAD IN REVERSE POLARITY!

This will activate the reverse polarity connection protection which will blow the internal output fuses in order to protect the device. The unit will be inoperable until these fuses have been replaced. See *Output Fuse Replacement* for more information.

CAUTION: NEVER USE A VOLTAGE CONVERTER UNIT TO CHARGE A BATTERY!

This unit does not have the necessary circuitry on the output to prevent current from back-feeding into the unit. Using this unit this way will damage it and is not covered under the Warranty.

Output Fuse Replacement

This unit features output reverse polarity connection protection. If a load or battery is connected to the output in reverse polarity, the output fuses will blow to protect the power supply or battery charger.

The unit cannot be used until the fuses are replaced. See the Specifications section for rating/ make of fuses. When replacing the fuses, ALL the fuses must be replaced as they operate in parallel.

CAUTION: BEFORE REPLACING THE FUSES, DISCONNECT THE UNIT FROM THE POWER SOURCE AND MAKE SURE THE POWER SWITCH IS OFF.

To prevent risk of high voltage electric shock, the unit must be fully disconnected from power before attempting to replace the output fuses.

TO REPLACE THE FUSES:

1. Loosen and remove the ten screws holding the front panel to the chassis.
2. Gently pull the front panel free from the main circuit board. The output fuses are mounted in fuse holders and their location is indicated by the red circle in the picture below.
3. Replace the old fuses with new fuses. The new fuses must be the same type and rating as the old ones. See *Specifications* for more information regarding output fuses.
4. The main circuit board connects to the front panel, via the black square shaped connectors above the fuses. Gently push the two together to seat them.
5. Make sure that the O-ring seal and gasket are properly seated. This is very important for the W/Y models in order to ensure a water-tight seal!
6. Re-insert all the front panel screws loosely, making sure none are cross threaded. Once all screws are started, tighten them in sequence. The screws are made from corrosion resistant stainless steel which is softer than regular steel, so take care to not over-tighten.
7. Reconnect the unit to power and check that it turns ON. Turn the unit OFF, and making certain that the polarity is correct, reconnect the load or battery to the output. Turning the unit ON, normal operation should resume immediately.



Pictured: Front panel circuit board. Output fuse location indicated by red circle.

Troubleshooting

This unit features several LED indicators and an alarm buzzer to help diagnose any malfunctions. The voltage converter will sound the buzzer to alert you prior to shutting down. You should immediately check which LEDs are glowing to determine the cause of the shutdown.

| Issue | Meaning |
|--|--|
| <p>LOW VOLTAGE IN LED is ON Alarm buzzer sounds</p> <p>Fix:</p> | <p>The input voltage is too low for normal operation or there may be an internal component failure.</p> <p>Check that the DC power source is rated for the application. Check that the input wiring and connections are not corroded or damaged.</p> <p>If everything is normal, the unit is defective and must be returned to the factory or an authorized service centre for repair.</p> |
| <p>OVER LOAD LED is ON Alarm buzzer sounds</p> <p>Fix:</p> | <p>The unit is over loaded. The connected devices are drawing too much current from the voltage converter.</p> <p>The voltage converter has been operating above its continuous current rating for longer than its intended duty cycle. Reduce the load by disconnecting some devices from the output.</p> |
| <p>OVER TEMP LED is ON Alarm buzzer sounds</p> <p>Fix:</p> | <p>The unit has overheated, its internal temperature is too hot for normal operation.</p> <p>Remount the unit for improved ventilation and cooling or disconnect some devices from the output to reduce heat generation.</p> <p>Check that the unit's cooling fans are functioning. If they are NOT, the unit is defective and must be returned to the factory or an authorized service centre for repair.</p> |
| <p>Unit will not turn ON</p> <p>Fix:</p> | <p>The input fuse has blown or there may be an internal component failure.</p> <p>Turn the voltage converter OFF and disconnect it from the power source and load. Then remove the input fuse and check if it has blown using an ohmmeter. Replace the fuse if blown.</p> <p>If the new fuse blows when the unit is turned ON or the unit still doesn't turn ON, the unit is defective and must be returned to the factory or an authorized service centre for repair.</p> |
| <p>LOW VOLTAGE OUT LED is ON OUTPUT ON LED is OFF</p> <p>Fix:</p> | <p>The output voltage is too low for normal operation. There may be a short on the output or there may be an internal failure.</p> <p>Disconnect all devices from the voltage converter and reconnect them one at a time, testing until you find the one responsible for shorting the output. The shorted device must be repaired.</p> <p>If the condition persists after all loads have been disconnected, then the unit is defective and must be returned to the factory or an authorized service centre for repair.</p> |

Remote Control Accessory



IMPORTANT: This remote can only be used on Voltage Converters manufactured by Analytic Systems.

The remote control panel and 9-pin D-connector are an optional feature for this product line. The remote control panel allows the unit to be operated remotely and duplicates all the diagnostic LED indicators with audible alarm. A built-in dimmer switch allows you to control the brightness of the remote control LEDs.

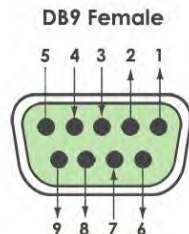

| Pin Number | Function |
|------------|--|
| 1 | Dry Contact Relay (Closed for fault) |
| 6 | Dry Contact Relay (Closed for fault) |
| 2 | Remote Off (Short to 5 to turn unit OFF) |
| 7 | OverTemp (Low for fault) |
| 3 | UnderVolt In (Low for fault) |
| 8 | OverLoad (Low for fault) |
| 4 | UnderVolt Out (Low for fault) |
| 9 | +12 Volts |
| 5 | Common |

CAUTION: DO NOT CONNECT THE REMOTE CONTROL WHILE THE UNIT IS ON!

To prevent the possibility of high voltage electrical shock, the voltage converter must be OFF while connecting the remote control. Do not remove the dust-cover on the remote control connector if it is not being used.

CAUTION: DO NOT CONNECT THIS PORT TO A COMPUTER!

This will cause serious damage to the voltage converter and computer. This damage is not covered under the warranty.

This page has been intentionally left blank.

Installation

Specifications

| Input | |
|--------------------|------------------------------|
| Nominal Voltage | 100-400 VDC |
| Maximum Input Amps | 16 Amps w. Inrush Protection |
| Input Fuse | 16-Amp 400 VDC |

| Output | | | |
|-----------------------|-----------------|---------------|---------------|
| Nominal Voltage | 12 VDC | 24 VDC | 48 VDC |
| Voltage Range (VDC)** | 12.0-15.5 VDC | 24.0-31.0 VDC | 48.0-62.0 VDC |
| Output Current | 110 A | 55 A | 28 A |
| Peak Amps | 132 A | 66 A | 33 A |
| Efficiency | 90% @ Full Load | | |

| Mechanical | |
|---------------------|---|
| Length | 17.4 in. / 44.2 cm |
| Width | 8.35 in. / 21.2 cm |
| Height | 4.0 in. / 10.2 cm |
| Clearance | 1.0 in. / 2.54 cm all around |
| Weight | 18.0 lb / 8.2 kg |
| Material and Finish | Marine-grade black anodized aluminum |
| Fasteners | 18-8 Stainless steel |
| Mounting | Vertical or horizontal mounting |
| Output Connection | DC Output: 2x sets of Phoenix VDFK Terminal Block (Red and Black) |
| Input Connection | AC Input: Type-D #12AWG Stranded Input Leads (Red: Positive, Black Negative) |

| Environmental and Safety | |
|-----------------------------|---|
| Operating Temperature Range | -25°C+ to +40°C (-40°C to +55°C Optional) |
| Storage Temperature Range | -55°C to +85°C |
| Humidity | 0 - 95% Relative Humidity (non-condensing) |
| Emissions | Complies with FCC Class B, Part 15 |
| Isolation | Input-Output, Input-Case, Output-Case: > 1500 VDC |
| Audible Noise | None (Ø db) |
| Duty Cycle | Continuous |
| Warranty | Five Years Parts and Labor |
| Safety | Built to meet ABS, CE, UL458 and CSA 22.2.107.1 |

* Specifications subjects to change without notice.

DESIGNED AND BUILT IN CANADA

//MDSPOWER®



800-931-4919

514-369-1919



order@mdspower.com



www.mdspower.com