

SPECIFICATIONS

		Input Voltage Range	Output Voltage	Output Current (Cont.)	Output Current (Peak)	Current Limiting	Line Regulation	Load Regulation	Output Ripple (Max)	Over-Voltage Protection	Efficiency (Typical)	Fuse
100-300 W	ICT2412-10A	20-30 VDC	13.8 VDC +/- 300 mV	10.0 Amps	10.0 Amps	10.5 Amps +/- 5%	1.00%	1.00%*	10 mV RMS	16.0 VDC	93%	10 Amp
	ICT2412-15A	20-30 VDC	13.8 VDC +/- 300 mV	14.0 Amps	15.0 Amps	17.0 Amps +/- 5%	1.00%	1.00%*	25 mV RMS	16.0 VDC	93%	15 Amp
	ICT2412-20A	20-30 VDC	13.8 VDC +/- 300 mV	18.0 Amps	20.0 Amps	21.0 Amps +/- 5%	1.00%	1.00%*	25 mV RMS	16.0 VDC	93%	20 Amp
300+ W	ICT2412-30A	20-30 VDC	13.8 VDC +/- 300 mV	25.0 Amps	30.0 Amps	31.0 Amps +/- 5%	0.50%	0.50%	50 mV RMS	16.0 VDC	95%	35 Amp
	ICT2412-40A	20-30 VDC	13.8 VDC +/- 300 mV	32.0 Amps	40.0 Amps	42.0 Amps +/- 5%	0.50%	0.50%	50 mV RMS	16.0 VDC	95%	35 Amp

NOTE: These converters can be mounted on a standard 19" Rackmount. Please contact us for more information.

The Remote On/Off feature is only available on Type 2 converters, and are shipped output-enabled by factory default.

* The load regulation is measured from 1Aout to rated peak current.

OUTLINE DRAWING

Dimensions in Inches

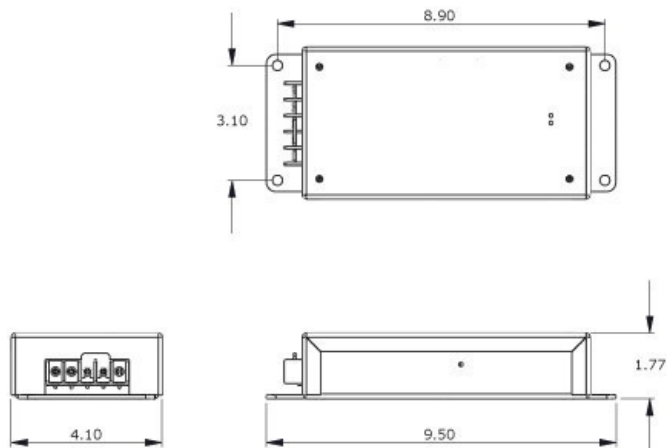

REMOTE ON/OFF FEATURE

- ▶ Units are shipped out output-enabled by factory default; a jumper is installed between the REMOTE and the input + terminals.
- ▶ To use the remote on/off feature, remove the jumper. Short / Open the REMOTE terminal to the input + terminals to turn the unit on / off.



ICT INDUSTRIAL SERIES (NON-ISOLATED) INSTRUCTION MANUAL



855-002-011

INNOVATIVE CIRCUIT TECHNOLOGY LTD.

ICT INDUSTRIAL SERIES

ICT Industrial Power Series converters are non-isolated DC to DC converters designed for use on negative ground systems. Each converter is designed for high efficiency and long service life. The rugged case and modular design have proven durable in harsh environments. Extra silicone is used for vibration and moisture resistance. Standard features include current limiting, overvoltage protection, fuse protection, high surge capacity, easy access mounting holes, and a terminal block connector.

These instructions should be read before using the product and saved for future reference.

SETUP

- ▶ Mount converter securely.
- ▶ Do not apply power until unit is completely wired.
- ▶ For best results, wire converter directly to battery using heavy gauge wire with in line fuse.
- ▶ NOTE: Do not wire output directly to a power source. Paralleling outputs are not recommended. Please contact technical support for application assistance.

WARNING

- ▶ Do not place unit on or near sources of heat/moisture.
- ▶ Incorrect wiring may result in serious damage to both the converter and connected equipment.
- ▶ Unit should be returned to ICT for service.

TROUBLESHOOTING

- ▶ Check fuse inside unit, if blown, replace with same type and rating fuse.
- ▶ Check for proper voltage at input while converter is under load.
- ▶ Check for erratic voltage conditions at input, which might cause overvoltage circuit to trigger.

CONNECTIONS

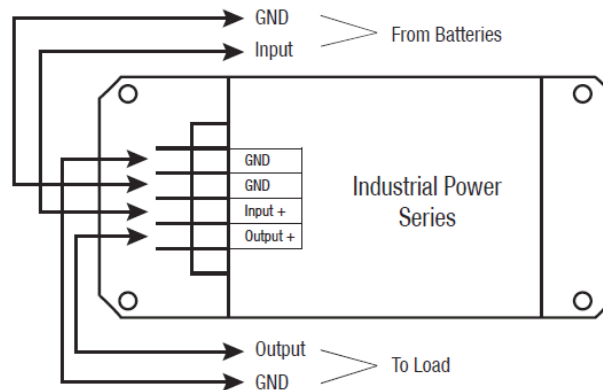

LIMITED WARRANTY

ICT Limited Warranty is only intended for the benefit of the original Purchaser of this product. This Warranty is not transferable or assignable without the prior written permission of ICT. ICT's sole obligation and liability under this warranty is limited to either repairing or replacing defective products at the sole discretion of ICT. When repairing or replacing the products, ICT may use products or parts that are new, equivalent to new or re-conditioned. Parts repaired or replaced during the warranty period will be under warranty for the remainder of the warranty period.

The warranty period on ICT products purchased new from ICT is two years. The warranty period for a repaired product or part thereof is ninety (90) days or the remainder of the unexpired term of the new product warranty period, whichever is greater. Repair or replacement of a defective product or part does not extend the original warranty coverage period.

No claim will be accepted unless written notice of the claim is received by ICT in accordance with ICT's Return Material Authorization (RMA) procedure, as soon as reasonably possible after the defect is discovered. A valid product serial number must be provided with the RMA claim to prove eligibility. The RMA form is available on the ICT website at www.ict-power.com/support/warranty-repair/.

The Purchaser shall at their own risk and cost return the defective product to ICT's factory or designated repair center once an RMA is issued by ICT. Return of the products to the customer after repair is completed shall be prepaid by ICT unless otherwise mutually agreed between the parties. Products shipped to ICT which have incurred freight damage will not be covered by this Warranty and any repairs or replacement parts, components or products needed will be invoiced in the full current price amount and returned freight collect to Purchaser. It is the Purchaser's responsibility to check the product upon receipt for any damage during shipping and to contact the carrier or shipper regarding such damage. Product that is returned as defective, which is determined to operate within published specifications will be returned to the Purchaser freight collect.

This Warranty will be void if the product has been subjected to misuse, neglect, accident, exposure to environmental conditions not conforming to the products' limits of operation, improper installation or maintenance, improper use of an electrical source, defects caused by sharp items or by impact pressure, a force majeure event, has been modified or repaired by anyone other than ICT or its authorized representative, has been subjected to unreasonable physical, thermal or electrical stress, improper maintenance, or causes external to the unit including but not limited to general environmental conditions such as rust, corrosive atmospheres, sustained temperatures outside the specified operating range of the equipment, exposure to power surges and/or electrical surges, improper grounding, mould or dust, animal or insect damage, water damage or immersion in liquid of any kind.

ICT does not control the installation and use of any ICT product. Accordingly, it is understood this does not constitute a warranty of performance or a warranty of fitness for a particular purpose.

